

Electronically Tunable Active Filters with Operational Transconductance Amplifiers

HENRIQUE S. MALVAR

Abstract—The design of voltage- or current-controlled active filters with operational transconductance amplifiers (OTA's) is much less expensive than with analog multipliers. This paper presents some experimental results on known circuits and a new configuration which allows the electronic control of the absolute bandwidth of a biquad circuit.

I. INTRODUCTION

In some applications, such as automatic control, music synthesis, small range spectrum analysis and speech synthesis, the need arises for filters with electronically controllable parameters. The classical approach to the realization of filters with linear control of the transfer function coefficients is to substitute some transmittances in the state-variable or biquad configuration [1]–[3] by

Manuscript received September 8, 1980; revised September 25, 1981.

The author is with the Department of Electrical Engineering, University of Brasilia, 70.910 Brasilia, DF, Brazil.

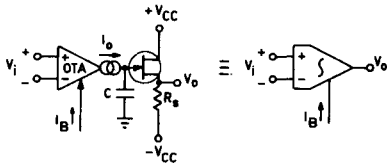

Fig. 1. The programmable integrator, with differential inputs. Following the integrating capacitor, a very high input impedance FET buffer must be used.

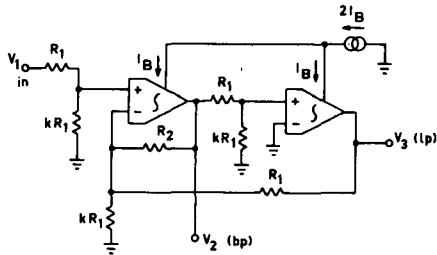

Fig. 2. The basic biquad structure with OTA's. The resonance frequency is directly proportional to the bias current I_B .

analog two-quadrant multipliers [4]. Other alternatives are the use of voltage-controlled impedances [5] or connecting transistors in a cascode-like configuration [6].¹

The use of the biquad with fixed integrators and multiplier-defined transmittances [4] has some problems: 1) first, analog multipliers are relatively expensive; 2) as the resonance frequency is increased, the signal levels at the output of each integrator become progressively lower and since these signals are used as inputs to analog multipliers, the signal-to-noise ratio decreases; 3) if each integrator has a pole at a frequency ω_p (since a pole at the origin is unrealizable) the resonance frequency of the filter cannot be lower than ω_p , which is an undesirable feature in control systems; 4) finally, the dynamic range of analog multipliers is not very high, which implies a reduced tuning range of the filter.

II. USING OPERATIONAL TRANSCONDUCTANCE AMPLIFIERS

A good alternative to the use of analog multipliers and fixed integrators is to embed the two functions in one block, the programmable integrator, which was independently proposed in two works [7], [8]. This building block, shown in Fig. 1, is based on the operational transconductance amplifier (OTA) loaded by a capacitor, creating an integration effect. The unity gain FET buffer is needed to ensure a very low-frequency pole.

Since the OTA is a differential pair with variable bias followed by current mirrors [9], its transconductance is given by

$$g_m \equiv \frac{I_o}{V_i} = \frac{I_B}{2V_T} \quad (1)$$

where V_T is the thermal voltage (26 mV at room temperature). So, the transfer function V_o/V_i in Fig. 1 is

$$\frac{V_o(s)}{V_i(s)} = \frac{g_m}{sC} = \frac{I_B}{2CV_T} \cdot s^{-1}. \quad (2)$$

Hence, the circuit of Fig. 1 is an integrator with a gain proportional to the bias current I_B . This programmable integrator block can be used in place of the fixed integrators of the biquad circuit, leading to the configuration of Fig. 2 [7]. Since the integrator of Fig. 1 has a differential input, the inverting ampli-

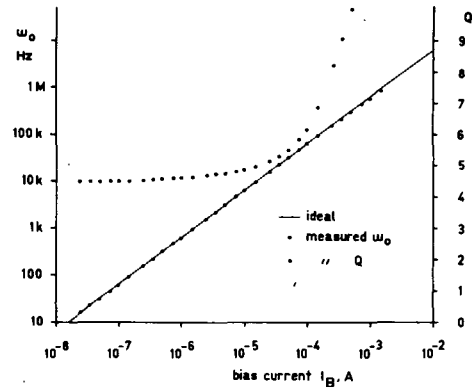

Fig. 3. Measurement of the tuning range of the filter in Fig. 2. The linearity of the tuning extends over five decades.

fier of the biquad structure can be eliminated, and the filter gain can be positive for both the bandpass and low-pass outputs.

Being that the input stage of the OTA is a differential pair, and since the OTA operates without local feedback, the input voltage V_i in Fig. 1 must not exceed $V_T/2$ peak for linear operation. This is the reason why there are voltage dividers at the inputs of the OTA's in Fig. 2. The attenuation parameter k must be reasonably low, being a value of 0.01 a reasonable compromise between distortion and signal-to-noise ratio.

Supposing $k \ll 1$ in Fig. 2, and applying (1), the responses of the filter can be obtained

$$\frac{V_2(s)}{V_1(s)} = \frac{\omega_o s}{s^2 + \frac{\omega_o s}{Q} + \omega_o^2} \quad (2)$$

and

$$\frac{V_3(s)}{V_1(s)} = \frac{\omega_o^2}{s^2 + \frac{\omega_o s}{Q} + \omega_o^2} \quad (3)$$

where

$$\omega_o \equiv \frac{kI_B}{2CV_T} \quad (4)$$

$$Q \equiv \frac{R_2}{R_1}. \quad (5)$$

So, bandpass and low-pass outputs are available at V_2 and V_3 , respectively. From (4) and (5) above it is seen that there are no sensitivities exceeding 1 in absolute value, which is a characteristic of the state-space topology used [2]. It can also be noted that the bias current I_B does not affect the Q factor and ω_o does not depend on R_2 . Hence, the Q setting is independent of the tuning, and vice versa.

Since (1) is valid over more than four decades [9] of the bias current I_B , ω_o can be tuned over the same range. This range cannot be much increased because of the leakage currents that deviate g_m from linearity as given by (1), and because of the ohmic drop across the silicon junctions of the differential input stage of the OTA. The later limits I_B to 400 μ A, because above this point g_m will be somewhat lower than the value predicted by (1).

A good characteristic of the filter in Fig. 2 is that the signal levels at any node of the circuit, at the frequency ω_o , do not vary with the tuning current I_B , which means that the distortion and noise of the circuit will be reasonably independent of the tuning.

The circuit of Fig. 2 was built with $R_1 = 47$ k Ω and $C = 50$ pF

¹Circuits like [6] were widely used in sound synthesizers because of their wide tuning range. At present, OTA filters are already present in sound synthesizers.

(including parasitic capacitances). The resonance frequency ω_0 and the Q factor were measured varying I_B from 22 nA to 1.5 mA, as shown in Fig. 3. The linearity of the resonance frequency tuning covers five decades and the Q increases at higher bias currents. This effect is the so-called Q -enhancement of the biquad topology [3], [7] due to the excess phase [10] introduced by the amplifiers, and can be compensated with the traditional phase-lead capacitor.

III. SLEW RATE ANALYSIS

The programmable integrator of Fig. 1 is based on a capacitor driven by a current source, which is exactly the arrangement responsible for the well-known slewing rate problem due to the limited rate of change of the capacitor voltage. Supposing, in Fig. 1,

$$V_0 \cong V_c = V_m \sin \omega t$$

it follows

$$\left| \frac{dV_c}{dt} \right|_{\max} = \omega V_m \tag{6}$$

Since the capacitor current cannot be greater than I_B , due to the internal structure of the OTA [9], there is a slewing rate limitation given by

$$V_m \leq \frac{I_B}{\omega C} \tag{7}$$

Comparing (4) and (7), the maximum peak output of each integrator can be written as

$$V_m \leq \frac{2V_T \omega_0}{k \omega} \tag{8}$$

Considering that in most applications $Q \gg 1$, there is a pronounced maximum at both filter outputs at $\omega = \omega_0$. So, for a sinusoidal output the slewing rate limit is

$$V_m \leq \frac{2V_T}{k} \tag{9}$$

So, if $k = 0.01$ as in Section II, the peak amplitude of both outputs must be lower than 5.2 V. It must be remembered, however, that the output current of the OTA will be highly distorted if V_m is near this maximum, because the differential input stage must go through its nonlinear region in order to source or sink a current near I_B into the integrating capacitor. From a practical viewpoint, the amplitude of the signal at the filter outputs must not exceed half the limit imposed by (9). If this condition is not met, a hysteresis in the frequency response will occur, with a reduction in the resonance frequency and a possibility of oscillation, due to the clipping at the integrator outputs.

IV. ELECTRONIC CONTROL OF THE BANDWIDTH

The structure of Fig. 1 realizes a tunable filter with fixed Q . If the later must be also electronically controlled, a third OTA can replace the resistor R_2 , as shown in Fig. 4 [7]. Calling \tilde{g}_m the transconductance of the third OTA, it is easy to see that the relative bandwidth $1/Q$ of the filter is

$$\frac{1}{Q} = \tilde{g}_m k R_1 = \frac{k R_1 I_{BQ}}{2V_T} \tag{10}$$

where I_{BQ} is the bias current of the third OTA. In this way, the relative bandwidth of the filter can be linearly controlled by the current I_{BQ} .

In order to investigate the stability of the relative bandwidth defined by (10) when ω_0 is changed, the circuit of Fig. 4 was built with $C = 380$ pF, $R_1 = 47$ k Ω , and $k = 0.01$, with the bias current

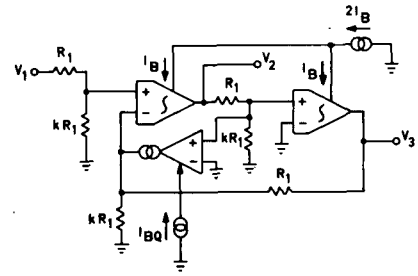

Fig. 4. Controlling the relative bandwidth with a third OTA.

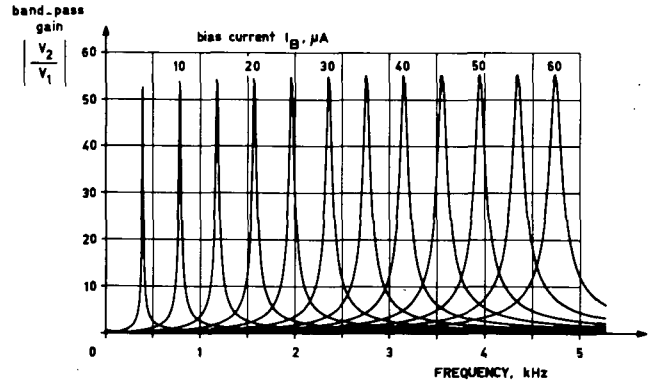

Fig. 5. Variation of the resonance frequency with I_{BQ} fixed at 2.0 μ A for the filter of Fig. 4.

of the third OTA kept at 2.0 μ A, corresponding to $Q = 55$, according to (10). The frequency response of the filter was measured with an HP 3580A spectrum analyzer connected to an X-Y plotter. The results are shown in Fig. 5, with I_B varying from 5 to 60 μ A, for the bandpass output. The apparent reduction of the Q for $I_B = 5$ μ A and 10 μ A is due to the minimum speed of the analyzer which was still high for the narrow bandwidths of these two curves.

The results on Fig. 5 show that if the filter is to be used in the kilohertz range, with C around hundreds or thousands of picofarads, the Q -enhancement problem is almost negligible.

Although the circuit of Fig. 4 allows the adjustment of the resonant frequency and the Q of the filter, there are applications where the absolute bandwidth of the filter must be independently controlled, as in speech synthesis [11] or spectrum analysis.

Using analog multipliers, a fixed bandwidth tuning can be achieved by creating a feedback loop around a fixed-gain integrator, as pointed out by Sparkes and Sedra [4]. At first sight, it might seem difficult to use this idea in the circuit of Fig. 2, since the filter is built around variable gain integrators. However, creating a feedback loop from the output of the first integrator to its integrating capacitor, a bandwidth control can be achieved, as shown in Fig. 6. Another alternative is presented in [12], but the later has some dc stabilization problems, calling for dc blocking capacitors.

If the transconductance of the third OTA is \tilde{g}_m , it is easy to verify that the absolute bandwidth B is given, in radians per second, by

$$B = \frac{\omega_0}{Q} = \frac{k \tilde{g}_m}{C} = \frac{k I_{BW}}{2C V_T} \tag{11}$$

where I_{BW} is the bias current of the third OTA. The circuit of Fig. 6 was built with $R_1 = 47$ k Ω , $k = 0.01$, and $C = 145$ pF. In order to investigate the bandwidth variation with tuning, the bias current of the third OTA was kept at 1.0 μ A, and the tuning

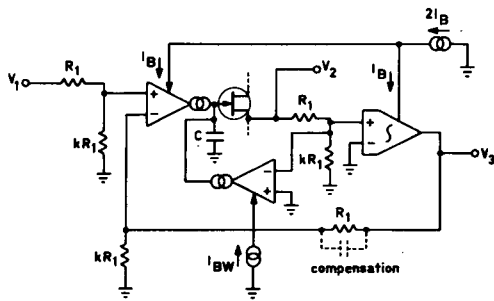

Fig. 6. This structure, similar to the filter of Fig. 4, allows the current control of the absolute bandwidth.

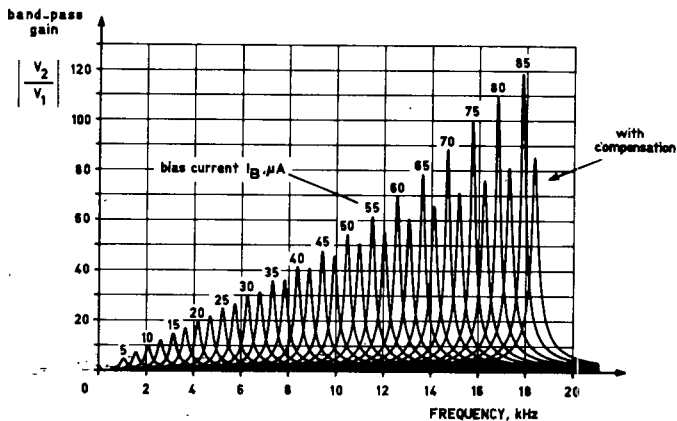

Fig. 7. Variation of the resonance frequency with constant bandwidth, in the filter of Fig. 6. The compensation capacitor eliminates the Q -enhancement effect (see text).

current I_B was varied. The measured responses at the bandpass output were plotted, and are shown in Fig. 7. Two groups of curves were plotted: the first, without the phase-lead compensation capacitor, corresponding to the I_B settings at multiples of $5 \mu\text{A}$ and the second with a 1.28 pF compensation capacitor,² corresponding to the I_B settings at odd multiples of $2.5 \mu\text{A}$. It can be seen from the curves of the compensated case that the gain at the resonance increases linearly with ω_0 , which corresponds to a constant bandwidth of 210 Hz . The rightmost curve of the compensated curve corresponds to a Q factor of about 86 at a resonant frequency of 18.4 kHz . These two parameters cannot be simultaneously achieved in active filters based on internally compensated operational amplifiers, which makes OTA filters attractive even for applications where the electronic tuning is not a requirement.

V. CONCLUDING REMARKS

This work has emphasized the advantages in using OTA's for the implementation of electronically programmable filters. The measured results have shown that a very good control linearity is achieved. The proposed structure for the absolute control of the bandwidth has worked well even for relatively high selectivities, and can be successfully used to build a formant filter in analog speech synthesizers.

²It should be noted that the Q -enhancement effect is dependent on the loading capacitances at the outputs of the filter. The curves of Fig. 7 were obtained without loading the low-pass output and with a 100-pF load capacitance (due to the measuring equipment and associated cables) on the bandpass output.

From the measured data it was observed that the filters built with OTA's can have relatively high Q factors (around 50) with a resonant frequency in the tens of kilohertz range. This performance, not achieved by filters based on internally compensated operational amplifiers like the 741 , is due to the fact that the bandwidth of the OTA increases with higher bias currents. This is also the reason why the observed Q -enhancement effects were not so abrupt.

Until now, the temperature influence on the filter was postponed, but it must be remembered that V_T is directly proportional to the absolute temperature. In applications such as speech synthesis or tracking filters this is not a great problem, but there are cases where the $0.33 \text{ percent}/^\circ\text{C}$ variation of V_T must be compensated. This is usually done by using PTC resistors (or a series-parallel combination) for the kR_1 resistances shown in all filters, since any filter parameter that depends on V_T depends in the same way on k^{-1} .

ACKNOWLEDGMENT

The author would like to thank to Prof. C. Lisboa for very stimulating discussions about OTA filters, and to one of the reviewers for his (or her) constructive critics.

REFERENCES

- [1] W. J. Kerwin, L. P. Huelsman, and R. W. Newcomb, "State-variable synthesis for insensitive integrated transfer functions," *IEEE J. Solid-State Circuits*, vol. SC-2, pp. 87-92, Sept. 1967.
- [2] J. Tow, "Active RC filters—a state-space realization," *Proc. IEEE*, vol. 56, pp. 1137-1139, June 1968.
- [3] L. C. Thomas, "The biquad: Part I—Some practical design considerations," *IEEE Trans. Circuit Theory*, vol. CT-18, pp. 350-357, May 1971.
- [4] R. G. Sparkes and A. S. Sedra, "Programmable active filters," *IEEE J. Solid-State Circuits*, vol. SC-8, pp. 93-95, Feb. 1973.
- [5] L. T. Bruton, "Electronically tunable analog active filters," *IEEE Trans. Circuit Theory*, vol. CT-19, pp. 299-301, May 1972.
- [6] J. B. Grimbleby, "Simple electronically tunable 2nd-order active filter," *Electron. Lett.*, vol. 13, no. 9, pp. 258-260, Apr. 28, 1977.
- [7] S. Franco, "Use transconductance amplifiers to make programmable active filters," *Electron. Design*, vol. 24, no. 19, pp. 98-101, Sept. 13, 1976.
- [8] T. Orr, "Voltage/current controlled filter," *Wireless World*, vol. 82, p. 63, Nov. 1976.
- [9] National Semiconductor Corp., Linear Data Book, 1980.
- [10] R. Schaumann, J. R. Brand, and K. R. Laker, "Effects of excess phase in multiple-feedback active filters," *IEEE Trans. Circuits Syst.*, vol. CAS-27, pp. 967-970, Oct. 1980.
- [11] J. L. Flanagan *et al.*, "Synthetic voices for computers," *IEEE Spectrum*, vol. 7, no. 10, pp. 24-45, Oct. 1970.
- [12] H. S. Malvar, "Voltage-controlled integrator sets filter's bandwidth," *Electronics*, vol. 53, no. 17, pp. 98-99, July 31, 1980.